



Overview

The GPSTran is designed to provide a vehicle speed signal to telematic or other equipment. The non-contact method of operation allows measurement of speed in applications where use of traditional speed sensors is not possible. Output is in digital pulse form with a frequency directly proportional to velocity. The velocity data is derived from Doppler measurement of GPS satellite carrier signals, with a 5Hz update rate. This Doppler measurement ensures an accuracy of within 0.1 km/h (0.0625mph) when an open view of the sky is available. Operational status is indicated through a tri-colour led. A recessed push-button switch is housed on the rear of the unit to initiate a GPS cold start after installation.



Applications

- Agricultural
- Telematics
- Trip recorders
- Taxi meters
- Data logging

Dimensions

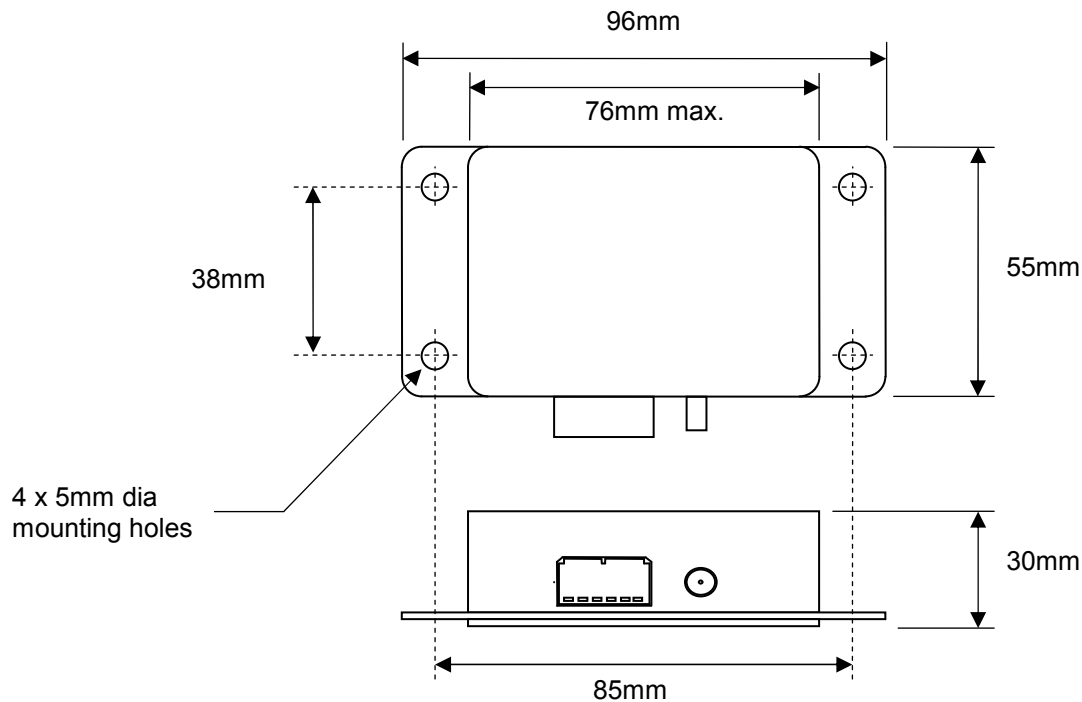



GPS

Update Rate	5Hz	Doppler Measurement
Velocity Accuracy	+/-0.1km/h	

Inputs

Power	Voltage	+8V to +40V DC (ignition switched feed)
	Current	Approx 130mA (fit 200mA in-line fuse)
GPS Antenna	SMA Type	
Cold Start	Push button switch	Press and hold for approximately 5 seconds until LED turns to orange then release
Test Output	Push button switch	Pressing for < 4 seconds will force 100km/h test signal on output

Output

Speed Output	Pulse per Metre	User adjustable from 0.1 to 100 pulses per metre. Default setting 10 pulses per metre
LED Status	Green*	Power on / Operation OK
	Red*	Power on / Low satellite count
	Amber	Power on / Cold start active
	No light	Power off

Main Connector 9type AMP multilock 040

Pin	I/O	Function	Wire Colour
1	I	Ground	Black
2	I	+8V to +40V Power. Ignition switched feed	Red
3	O	Speed Pulse (0 to Vpower)	Orange
4	O	Reserved	
5	O	RS232 Tx (Configuration only)	
6	I	RS232 Rx (Configuration only)	

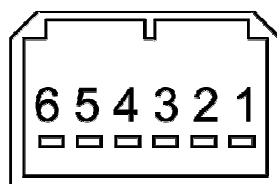

Mating connector
AMP / Tyco 175507-2
Contact terminals 175062 or 345160

GPS Antenna (Type SMA)

Centre Pin	Signal / Active antenna bias +5VDC
Shield	Ground