

VBOX 3i v2

100Hz GPS Data Logger



VBOX 3i v2 is one of the best known and highly valued test instruments for non-contact speed and distance measurement. Using a powerful GPS engine, VBOX 3i v2 logs data at 100 times a second and features a 400MHz power PC processor. With IMU integration, USB and Bluetooth connectivity, compact flash card logging and audio functionality for voice tagging, the VBOX 3i v2 represents a flexible solution to a range of testing requirements.

When used with an (optional) DGPS BaseStation, VBOX 3i v2 is capable of achieving 40cm 95% CEP positional accuracy. This enables users to measure parameters within acceleration, deceleration, braking, ABS and ESP testing, handling manoeuvres and many other types of high dynamic testing.



As with previous VBOX models, VBOX 3i v2 is compatible with all existing peripherals, including Multifunction Display, 16bit Analogue Input, 4 Channel Frequency Input Module, 8 Channel Thermocouple Interface and Yaw rate sensor.



For accurate testing, even in areas where the view of the sky is obstructed, VBOX 3i v2 has the ability to gather additional information from an IMU (Inertial Measurement Unit – pictured below) and combine this with the GPS data in real-time to improve the quality of the parameters measured. To keep track of the attitude of the vehicle and greatly increase the velocity and position accuracy during periods when satellite visibility is poor, the IMU uses three accelerometers and gyros.

Features

- Non-contact 100Hz speed and distance measurement using GPS
- Very low latency: 6.75ms
- 4 x 24bit differential analogue input channels with $\pm 50v$ input range and synchronous capture
- Brake/Event Trigger input of 10ns resolution.
- 2 x CAN Bus interface for data input & output
- RS-232 serial interface
- USB Interface
- Bluetooth Interface
- Audio voice tagging
- Microphone headset included
- Data logged to Compact Flash memory card
- 2 x 16bit User configurable analogue outputs
- 2 x Digital outputs
- User configurable logging conditions
- Logging rate selectable to 100Hz, 50Hz, 20Hz, 10Hz, 5Hz, 1Hz
- Wide 7V to 30V operating range
- Low current consumption
- Positional accuracies of 2cm with RTK basestation

VBOX 3i v2

100Hz GPS Data Logger



System

GPS

VBOX 3i v2 features a powerful GPS engine capable of providing 100Hz update rate for all GPS parameters (including velocity, heading and position). Velocity and heading data are calculated from Doppler Shift in the GPS carrier signal, providing users with unparalleled accuracy.

IMU Integration

VBOX 3i v2 has the ability to utilise data from a Racelogic IMU to improve all parameters measured in real-time. A useful tool when in areas suffering from poor satellite reception (e.g. near trees, buildings or bridges). All captured data is processed at 100Hz, improving accuracy/noise levels and enhancing the dynamic response to velocity. Parameters smoothed by this process include velocity, position, height, lateral and longitudinal acceleration and vertical velocity. IMU integration also effectively combats complete satellite dropout up to a maximum time period of 10 seconds without lock.

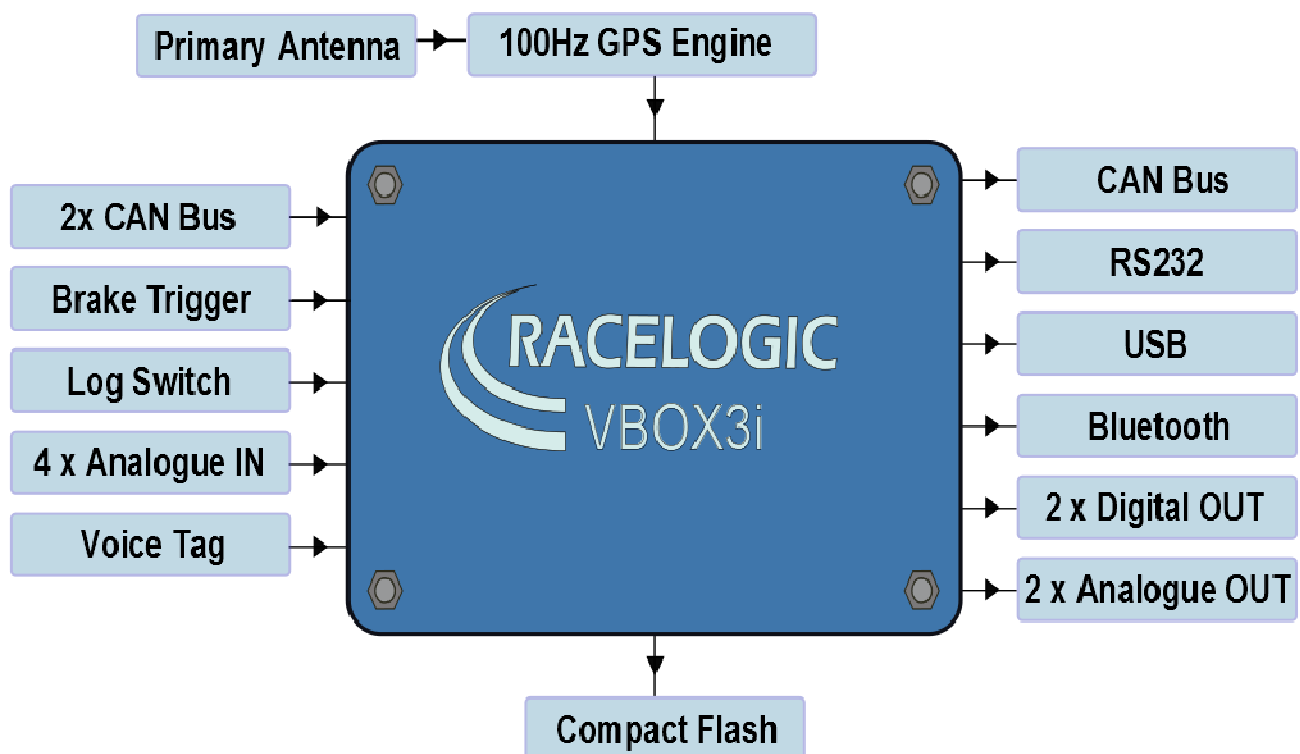

Compact Flash

VBOX 3i v2 can accept Type I compact flash cards to log data. Data is stored in a standard PC format allowing fast transfer of data to a PC equipped with a compact flash card reader. The file format is an ASCII text file that can be loaded directly into VBOX Tools software, or imported into Excel and other third party software.

VBOX 3i v2

100Hz GPS Data Logger



Inputs/ Outputs

Inputs	Outputs
<p>CAN Bus Two CAN Bus interfaces are available on VBOX 3i v2. By utilising separate CAN Bus connections it allows data to be logged from external modules (e.g. TC8, FIM02). Up to 16 CAN signals can also be logged from a different CAN source (e.g. Vehicle CAN Bus). When logging data from another source, VBOX Tools can load signal data from an industry standard CAN database file (.DBC).</p>	<p>CAN Bus One of the two VBOX CAN ports can be used to output VBOX GPS parameters plus any 12 channels from connected input modules or internal AD channels. The baud rate and CAN id's for these outputs are user configurable.</p>
<p>Brake Trigger By using a physical pressure switch on the brake pedal, a precise 'start of braking event' can be captured.</p>	<p>RS232 RS232 connector is used for VBOX configuration and output of real-time GPS data. Serial data sent to the software is limited by the bandwidth of the PC serial port - 20Hz. (Full 100Hz serial is available via USB / Bluetooth.)</p>
<p>Log Switch A start/stop logging switch allows users to manually choose when they wish to record data.</p>	<p>USB VBOX 3i USB connector can be used for VBOX Configuration to output real-time data at 100Hz.</p>
<p>4x Analogue Input Each of the four Analogue Input channels on a VBOX 3i have a dedicated 24bit analogue converter. Data is recorded from each channel simultaneously to avoid latency between analogue channel data. The name, scale and offset of each Analogue Input channel can be adjusted using VBOX Tools software to allow sensor calibration and therefore logging of data in standard SI units. The Analogue Input connector also provides two power outputs that may be used for driving sensors. These are in the form of a 5v DC isolated supply and an output equal to the VBOX power supply voltage.</p>	<p>Bluetooth VBOX 3i comes equipped with an internal Bluetooth Radio allowing remote configuration and remote output of real-time GPS data to any Bluetooth capable PC or Data logger. The Bluetooth connection is capable of sending data at the full 100Hz rate.</p>
<p>Voice Tagging VBOX 3i can record a GPS synchronised WAV audio tag up to 30 seconds long to a time accuracy of 0.5 sec. The recorded WAV file is then logged to the CF card.</p>	<p>2x Digital Outputs Two digital outputs are available on VBOX 3i v2. One Digital output is assigned to Speed/Distance – configurable via Pulses per Meter. While the second is a level switch output enabling users to select any one of the logged channels and assign it a threshold value.</p>
<p>Power Supply VBOX 3i can accept a supply voltage between 7 to 30V DC. Low current consumption results in extended battery life.</p>	<p>2x Analogue Outputs 2x 16bit analogue outputs can be configured to output velocity (or other GPS parameters) for use by additional data logging equipment. The voltage output range is from 0 to 5v DC with a resolution of 76 μV per bit.</p>

VBOX 3i v2

100Hz GPS Data Logger



GPS Specifications

Velocity		Distance	
Accuracy	0.1 Km/h (averaged over 4 samples)	Accuracy	0.05 % (<50cm per Km)
Units	Km/h or Mph	Units	Metres / Feet
Update rate	100 Hz	Update rate	100 Hz
Maximum velocity	1000 Mph	Resolution	1 cm
Minimum velocity	0.1 Km/h	Height accuracy	6 Metres 95% CEP**
Resolution	0.01 Km/h	Height accuracy with DGPS	2 metres 95% CEP**
Latency	6.75 ms		

Absolute Positioning		Time	
Accuracy	3m 95% CEP**	Accel/Brake Test (MFD/VBOX Tools)	
Accuracy with SBAS DGPS	<1m * 95% CEP**	Resolution	0.01 s
Accuracy with RTCM DGPS	40cm 95% CEP**	Accuracy	0.01 s
Accuracy with RTK DGPS	2cm 95% CEP** (optional)	Lap Timing (OLED/VBOX Tools)	
Update rate	100 Hz	Resolution	0.01 s
Resolution	1.8 mm	Accuracy	0.01 s*

*To be confirmed

Heading		Brake stop accuracy	
Resolution	0.01°	Accuracy	+/- 2cm
Accuracy	0.1°		

Acceleration		Environmental and physical	
Accuracy	0.50%	Weight	Approx. 900 grams
Maximum	20 G	Size	170 x 121 x 41mm
Resolution	0.01 G	Operating temperature	-20°C to +70°C
Update rate	100 Hz	Storage temperature	-30°C to +80°C

Memory		Power	
Compact Flash	Type I	Input Voltage Range	7 – 30V DC
Recording time	Dependent on flash	Power	Max. 5.5 Watts

Differential GPS
VBOX 3i v2 works in SBAS or RTCM DGPS modes (all accuracies listed in 95% CEP above)
SBAS DGPS offers ±1m accuracy and requires no additional equipment
RTCM DGPS offers ±40cm accuracy (requires BaseStation RLVBS4)
RTK DGPS offers ±2 cm accuracy (requires RTK option and RLVBS4RG)

Definitions

* Not using DGPS and crossing the start/finish line at 100km/h

** CEP = Circle of Error Probable. 95% CEP means 95% of the time the position readings will fall within a circle of the stated radius. 2cm accuracy requires an RTK option and RTK enabled Base Station

*** Approximately 29Mb per hour used when logging GPS data at 100Hz; Approx. 182Mb per hour total logging capacity



VBOX 3i v2

100Hz GPS Data Logger



Inputs

CAN Bus	
Racelogic modules	Up to 32 channels from any combination of ADC02, ADC03, FIM02, TC8, Yaw sensor or CAN01
External CAN Bus	16 Channels of user definable CAN signal from external bus, e.g. Vehicle CAN bus Can load signal data from industry standard DBC database file

Analogue		Digital	
Number of channels	4	Brake event trigger	10ns resolution
Input range	±50v	On/Off logging control	Remote log control from hand-held switch
Channel sample order	Synchronous		
Resolution	24 bit		
DC accuracy	400 µV		

Outputs

CAN Bus	
Bit rate	125Kbits, 250Kbits ,500Kbits & 1Mbit selectable baud rate
Identifier type	Standard 11bit 2.0A
Data available	Satellites in View, Latitude, Longitude, Velocity, Heading, Altitude, Vertical Velocity, Distance, Longitudinal Acceleration & Lateral Acceleration, Distance from Trigger, Trigger Time, Trigger Velocity

Analogue		Digital	
Voltage range	0 to 5Volts DC	Frequency range	DC to 44.4Khz
Default setting *	Velocity 0.0125Volts per Km/h (0 to 400Km/h)	Default setting *	Velocity 25Hz per Km/h (0 to 400Km/h) 90 pulses per metre
Accuracy	0.1 Km/h	Accuracy	0.1Km/h
Update rate	100Hz	Update rate	100Hz

Definitions

* The range settings can be adjusted by the user in VBOX Tools Software

VBOX 3i v2

100Hz GPS Data Logger



Hardware & Software Support

Support	
Hardware	One Year Support Contract
Software	Lifetime Support Contract: Valid for a minimum of 5 years from the date of purchase and limited to the original purchaser. Contract includes: telephone/ email technical support provided by local VBOX Distributor and firmware/ software upgrades (where applicable).

Package Contents

Description	Product Code
1x 100Hz GPS data logger	RLVB3i-V2
1x Mains Charger	RLVBACS020
1x 12VDC cigar lighter, 2-way LEMO power lead (1m)	RLCAB010L
2x Spare fuse 3.15A 250V	415 - 610
1x GPS L1 Antenna TW2010	RLACS158
1x Antenna cable, 4m, SMA-SMA, RG-174	RLCAB071-4
1x 4GB Compact Flash card	RLACS098
1x USB Multi-card reader	RLACS163
1x 5-way LEMO to 9-way D-type serial cable (2m)	RLCAB001
1x 25-way D-type connector	ADC25IPCON
1x VBOX Padded carry case	RLVBACS013
1x USB A – Mini B Lead	RLCAB066-2
1x VBOX Audio Headset	RLACS120
1x VBOX User Manual	VB3iMAN
1x VBOX Tools Manual	VBTOOLSMANA5
1x VBOX Tools Software CD	RLVBACS030
1x Bluetooth Antenna	RLACS119
1x Software Support Contract	RLVBSWSL3
1x VBOX 3i Cable Identification	VB3i-CABDEN