

VB2SX10 10Hz GPS Data Logger

User Guide





Contents

CONTENTS	2
INTRODUCTION	4
FEATURES.....	4
STANDARD INVENTORY.....	5
OPERATION.....	6
DISPLAY SCREEN	6
FRONT PANEL CONTROLS	7
MEMORY CARDS	11
GETTING STARTED.....	17
VB2SX10 ‘.VBO’ FILE FORMAT	19
VBOXTOOLS SOFTWARE	20
UPGRADING THE FIRMWARE	21
SPECIFICATION	22
CONNECTOR ASSIGNMENTS	24
CAN BUS DATA FORMAT	26
MODULE DIMENSIONS.....	27
FUSE RESET BUTTON	27
CONTACT INFORMATION.....	28

EC Declaration of Conformity

We declare that this product has been tested to and meet the requirements of:

EC Directive 2004/104/EC

“Adapting to Technical Progress Council directive 72/245/EEC relating to the radio interference (Electromagnetic Compatibility) of vehicles and amending directive 70/156/EEC on the approximation of the laws of the member states relating to the type-approval of motor vehicles and their trailers.”

And has also been assessed, via Technical Construction File, by an independent DTI Competent Body and found to be in conformance with the essential requirements of:

EC Directive 89/336/EEC (and amending directives)

“Council Directive of 03 May 1989 on the approximation of the laws of the member states relating to electromagnetic compatibility.”

DTI Competent Body responsible for issuing certificate of compliance:

3C Test Ltd,
Silverstone Technology Park,
Silverstone,
Northants
NN12 8GX

Introduction

The VB2SX10 represents the 2nd generation of GPS data logging system from Racelogic, updating the popular VBOXII and VB2S products with SD card logging and USB communications. Using a powerful GPS engine, the VB2SX10 can log GPS and other data at 10Hz. The logged data is stored directly onto a SD card for easy transfer to a PC.

The VB2SX10 is compatible with all of the existing peripherals including the Multifunction display, ADC03, TC8, FIM02, Yaw Rate Sensor and Speed Sensor with Slip Angle.

Features

- Non-contact 10Hz speed and distance measurement using GPS
- 1 x CAN Bus interface (on two sockets to allow daisy-chaining)
- USB interface for live data, upgrading and SD data transferral
- RS-232 serial interface backup for live data and upgrading
- SD Card logging
- 2 x 16bit user configurable analogue outputs (velocity)
- 2 x Digital outputs (velocity)
- Brake trigger input with 210KHz scan rate
- Input voltage 6V to 30V operating range
- Logging rate selectable from 10Hz, 5Hz, 2Hz, 1Hz

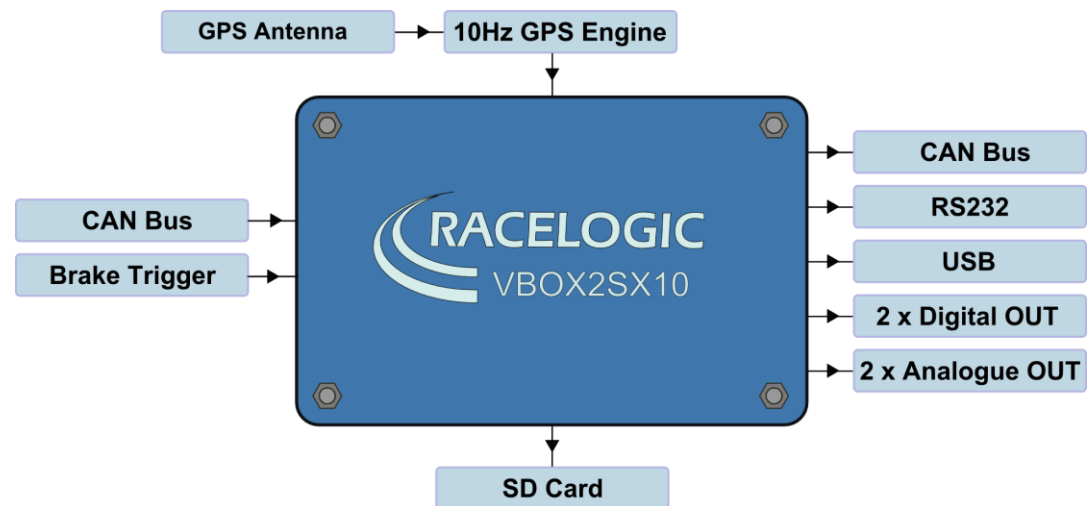

Standard Inventory

Description	Qty	Racelogic Part #
VB2SX10	1	VB2SX10
Mains Charger	1	RLVBACS020
Cigar Lighter adaptor	1	RLCAB010L
USB Lead	1	RLCAB042
PC Serial Cable	1	RLCAB001
2GB SD Card	1	RLACS083
GPS Magnetic Aerial	1	RLVBACS018
CD ROM containing VBOX software	1	RLVBACS030
VBOX IISX 10 User Manual	1	VB2SX10MAN
VBOX Tools software manual – A5	1	VBTOOLSMAA5
Padded Carrying Case	1	RLACS106

Operation

Display Screen

The Display screen will display data when operating it also displays all the menus required to configure the VB2SX10 via the front panel controls.

On start-up, the display screen shows the unit's firmware version.

During normal operation, the display screen displays Speed (mph or km/h) and the logged file name, as well as the number of satellites that the VB2SX10 has locked on to. There are also two satellite status displays.



OK (Green):

Indicates that the VB2SX10 has sufficient satellites locked to allow normal operation.

SATS (Yellow):

This flashes to indicate that the VB2SX10 has insufficient satellites and will not be able to operate at all.

WAAS/40cm (Orange):

This indicates that the corresponding DGPS corrections are available and being used by the unit.

Logged File name:

When an SD card is inserted the file name of the logged file appears on the screen whilst the file is open. A small disk icon to the left of the file name indicates that data is being logged.

Front Panel Controls

The VB2SX10 can be configured using the front panel buttons, which enables configuration without the need for a computer.

From the main screen, press the '■' button to enter the configuration screen.

Once in the configuration screen, press the '◀' and '▶' buttons to highlight the next or previous choice in any menu, and press '■' to select the highlighted option. Some menus contain sub-menus, for example the Analogue and Digital Output menus contain separate menus for each parameter.



Main Menu

SETTINGS	COLD START	SMOOTHING	OUTPUTS	EXIT
<p>Press '■' and then the '◀' and '▶' buttons to enter settings options sub-menus.</p> <p>UNITS USB MODE CAN MODE LOG OPTIONS SERIAL RATE GPS TIME OFFSET BACK</p>	<p>Press '■' to perform a GPS cold start</p>	<p>Press '■' to enter the Smoothing options sub-menus</p> <p>LAT ACC LONG ACC</p> <p>Press '■' to enter sub menu and '◀' and '▶' buttons to amend smoothing levels in 0.1 increments.</p>	<p>Press '■' to enter the outputs options sub-menus.</p> <p>DIGITAL 1 DIGITAL 2 ANALOGUE 1 ANALOGUE 2</p>	<p>Press '■' to exit the setup menu and cause the settings to be saved in EEPROM</p>



Settings Menu

UNITS	USB MODE	CAN MODE	LOG OPTIONS	SERIAL RATE
<p>Press the '◀' and '▶' buttons to choose between the following units:</p> <p>Km/h</p> <p>MPH</p> <p>KNOTS</p>	<p>Press the '◀' and '▶' buttons to choose between the following USB options:</p> <p>SERIAL PORT</p> <p>CARD READER</p>	<p>Press '■' and then the '◀' and '▶' buttons to choose between the following modes:</p> <p>VCI MODE*</p> <p>To connect any external CAN modules to the input of the VB2SX10</p> <p>RACELOGIC MODULES MODE</p> <p>To connect Racelogic CAN modules to the RLVB2SX10 (input or output)</p>	<p>Press the '◀' and '▶' buttons to choose between the logging options:</p> <p>LOG CONDITIONS:</p> <p>To select either Log Continuously or log When Moving</p> <p>LOG RATE:</p> <p>Select log rate – either 10, 5, 2 or 1Hz</p> <p>BACK</p> <p>Return to Settings menu</p>	<p>Press '■' and then the '◀' and '▶' buttons to choose between the serial data rates:</p> <p>Choose from either 10, 5, 2 or 1Hz</p>
GPS	TIME OFFSET	BACK		
<p>Press the '◀' and '▶' buttons to choose between the GPS options:</p> <p>DYNAMIC MODE</p> <p>DGPS MODE</p> <p>KALMAN FILTER</p> <p>BACK</p>	<p>Press the '◀' and '▶' buttons to offset the UTC time in 30 minute intervals to allow the VBOX to represent local time.</p>	<p>Press '■' to return to the settings menu</p>		

*Note: In VCI Mode, the VB2SX10 cannot output CAN data or input data from Racelogic modules.

SETTINGS - GPS MENU

DYNAMIC MODE	DGPS MODE	KALMAN FILTER	BACK
<p>Press '■' and then the '◀' and '▶' buttons to select the required dynamics.</p> <p>HIGH DYNAMICS Essential for brake testing and lane changing manoeuvres.</p> <p>NORMAL Select this for standard testing – speed, distance, etc.</p> <p>LOW DYNAMICS Select this for route mapping and similar tests where the level of dynamic response is not important.</p>	<p>Press '■' and then the '◀' and '▶' buttons to select the DGPS settings.</p> <p>OFF No DGPS applied – standard position accuracy 3m CEP</p> <p>WAAS – position accuracy 1.8m CEP</p> <p>40CM – position accuracy 40CM*</p> <p>20CM – position accuracy 20CM*</p>	<p>Press '■' and then the '◀' and '▶' buttons to set Kalmann filter options.</p> <p>POSITION LEVEL Smoothes the positional data</p> <p>VELOCITY LEVEL Smoothes the velocity data</p>	<p>Press '■' to return to the GPS menu</p>

*Note: These accuracies are only achievable in conjunction with a DGPS base station

OUTPUTS MENU (Channel 1 and 2)

DIGITAL 1	DIGITAL 2	ANALOGUE 1	ANALOGUE 2	BACK
<p>Press '■' and then the '◀' and '▶' buttons to select output conditions for digital output 1</p> <p>OUTPUT: PULSES PER METRE (velocity) MAX VELOCITY (velocity) MAX VALUE (Lat ACC & Long ACC) MAX FREQUENCY (Lat ACC & Long ACC) TEST BACK</p>	<p>Press '■' and then the '◀' and '▶' buttons to select output conditions for digital output 2</p> <p>OUTPUT: PULSES PER METRE (velocity) MAX VELOCITY (velocity) MAX VALUE (Lat ACC & Long ACC) MAX FREQUENCY (Lat ACC & Long ACC) TEST BACK</p>	<p>Press '■' and then the '◀' and '▶' buttons to select output conditions for analogue output 1</p> <p>OUTPUT: VALUE @ +5V VALUE @0V (Velocity) VALUE @ -5V (Lat ACC & Long ACC) TEST BACK</p>	<p>Press '■' and then the '◀' and '▶' buttons to select output conditions for analogue output 2</p> <p>OUTPUT: VALUE @ +5V VALUE @0V (Velocity) VALUE @ -5V (Lat ACC & Long ACC) TEST BACK</p>	<p>Press '■' to return to the main menu</p>



DIGITAL SETUP MENU (Digital 1 and Digital 2)

OUTPUT	VELOCITY PULSES PER METRE	VELOCITY MAX VELOCITY	LONG ACC / LAT ACC MAX VALUE	LONG ACC / LAT ACC MAX FREQUENCY
<p>Press '■' and then use the '◀' and '▶' buttons to select from:</p> <p>Velocity Long ACC Lat ACC</p>	<p>Press '■' and then use the '◀' and '▶' buttons to set the number of pulses per metre. Then press '■' to confirm.</p> <p>0.1-120 pulses per metre in 0.1 steps</p>	<p>Press '■' and then use the '◀' and '▶' buttons to set the level of the maximum Velocity. Then press '■' to confirm.</p> <p>0-400km/h in 0.1km/h steps</p>	<p>Press '■' and then use the '◀' and '▶' buttons to set the level of the maximum Long ACC or Lat ACC level. Then press '■' to confirm.</p> <p>0.5g to 2g in 0.1 g steps</p>	<p>Press '■' and then use the '◀' and '▶' buttons to set the frequency of the maximum Long ACC or Lat ACC level. Then press '■' to confirm.</p> <p>1-50kHz in 0.1kHz steps</p>
TEST	BACK			
<p>Press '■' and then use the '◀' and '▶' buttons to set a test value that the Digital output will simulate. Then press '■' to quit.</p>	<p>Press '■' to exit the digital setup menu and cause the settings to be saved in EEPROM</p>			

ANALOGUE SETUP MENU (Analogue 1 and Analogue 2)

OUTPUT	VALUE @ +5V	VALUE @ -5V (0V for Velocity)	TEST	BACK
<p>Press '■' and then use the '◀' and '▶' buttons to select from:</p> <p>Velocity Long ACC Lat AC</p>	<p>Press '■' and then use the '◀' and '▶' buttons to set the Velocity, Long ACC or Lat ACC level to represent +5V. Then press '■' to confirm.</p> <p>1-400km/h in 1km/h steps, or -1g to 2g in 0.1 g steps</p>	<p>Press '■' and then use the '◀' and '▶' buttons to set the Velocity, Long ACC or Lat ACC to represent 0V (velocity) or -5V (Lat ACC & Long ACC). Then press '■' to confirm.</p> <p>0-399km/h in 1km/h steps, or -2g to 1g in 0.1g steps</p>	<p>Press '■' and then use the '◀' and '▶' buttons to set a test value that the analogue output will simulate. Then press '■' to quit.</p>	<p>Press '■' to exit the analogue setup menu and cause the settings to be saved in EEPROM</p>

Memory Cards

The VB2SX10 stores logged data onto SD Cards. The supplied SD cards are already optimised for use on the VB2SX10 and as such do not need formatting before use. Should the SD Card need formatting due to card errors, this can be done through Windows by right clicking the SD card in the 'Computer' section and selecting 'Format'. The SD Card will need to be inserted into an SD Card reader (or a VB2SX10 set to 'Card Reader' USB Mode) for this to work.

When logging data to an SD Card the OLED display will show the name of the current file at the bottom of the display. It is important not to remove the SD Card while the VB2SX10 is logging. If the card is removed while the VBOX is writing data to it, there is a risk that the data file may be corrupted resulting in loss of data. If '**Log only when moving**' is the logging mode selected then wait a short time after the vehicle has stopped for logging to finish and the filename to disappear from the screen. If '**Log continuously**' is selected, press the Start/stop logging switch if connected or enter then exit the on-board configuration screen.

It is recommended that files are removed from the disk regularly as writing continuously with out fragments is easy. The more file fragments the harder it is to stream data to the card.

GPS Antenna

The GPS Antenna supplied with the VB2SX10 is a 3.5v active antenna. For the best possible signal quality, it is important to maintain a clean connection between the antenna and the VBOX. Before fixing the antenna to the VBOX, ensure that there are no dust particles in either connector. Replacement antennas are available by contacting your VBOX distributor.

The antenna is a magnetic mounting type for quick and simple mounting to the vehicle roof. For optimum GPS signal reception, make sure that the antenna is fitted to the highest point of the vehicle away from any obstructions that may block satellite reception. The GPS antenna works best with a metal ground plane underneath (eg. Vehicle roof). Please also note that when using any GPS equipment, a clear sky view is important. Objects in the surrounding area such as tall buildings or trees can block the GPS signal causing a reduction in the number of satellites being tracked, or introducing reflected signals that can decrease the accuracy of the system.

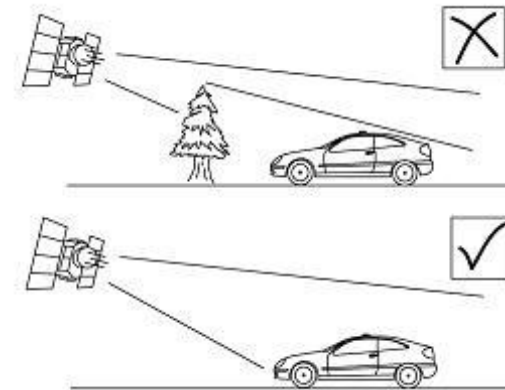

GPS antennas require a ground plane to operate correctly. Usually, the metal roof of a vehicle performs this function. However, if a test requires an antenna to be placed off of the vehicle, then a special Ground Plane ‘mushroom-style’ antenna must replace the off-vehicle antenna, as these antennas are capable of operating without a ground plane. The Ground Plane ‘mushroom’ style antennas RLVBACS065 are available from your VBOX distributor.



RLVBACS065 “mushroom” type Ground Plane Antenna

DIGITAL and ANALOGUE OUTPUTS

The digital outputs on connectors OUT1 and OUT2 are a frequency/pulse output corresponding to velocity, long ACC and Lat ACC. The frequency range is adjustable in software or via the front panel controls.

The analogue outputs on connectors OUT1 and OUT2 output a 0V to +5V DC signal corresponding to velocity and a -5V to +5V signal corresponding to Long ACC and Lat ACC. The volts range is adjustable in software or via the front panel controls.

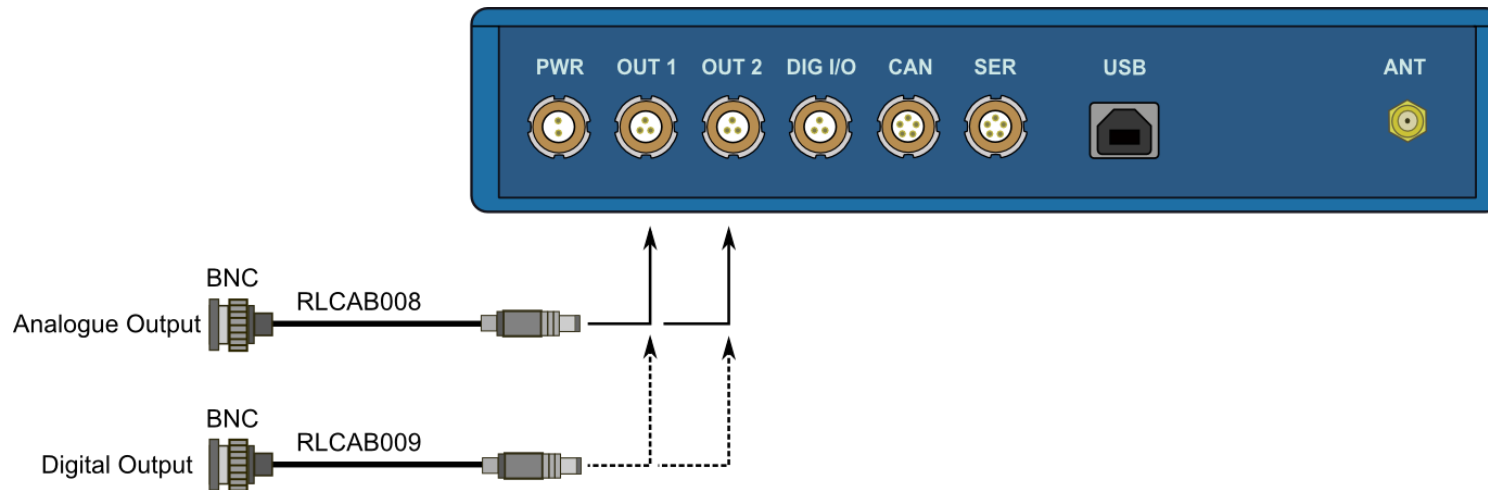

Digital Inputs

The DIGITAL I/O socket contains the two digital inputs for the VB2SX10. Digital input 1 is also referred to as the Brake trigger input. This input is connected to an internal timer capture module that is able to record precisely an event time for use in brake distance calculation. This period of time is called the trigger event time, and is logged as the value in milliseconds between the trigger event and the last GPS sample.

A hand-held brake trigger is also available to allow the user to record marker events in the VB2SX10 data file. A remote logging on/off switch is also available for ease of use and when the front panel switch is not accessible.

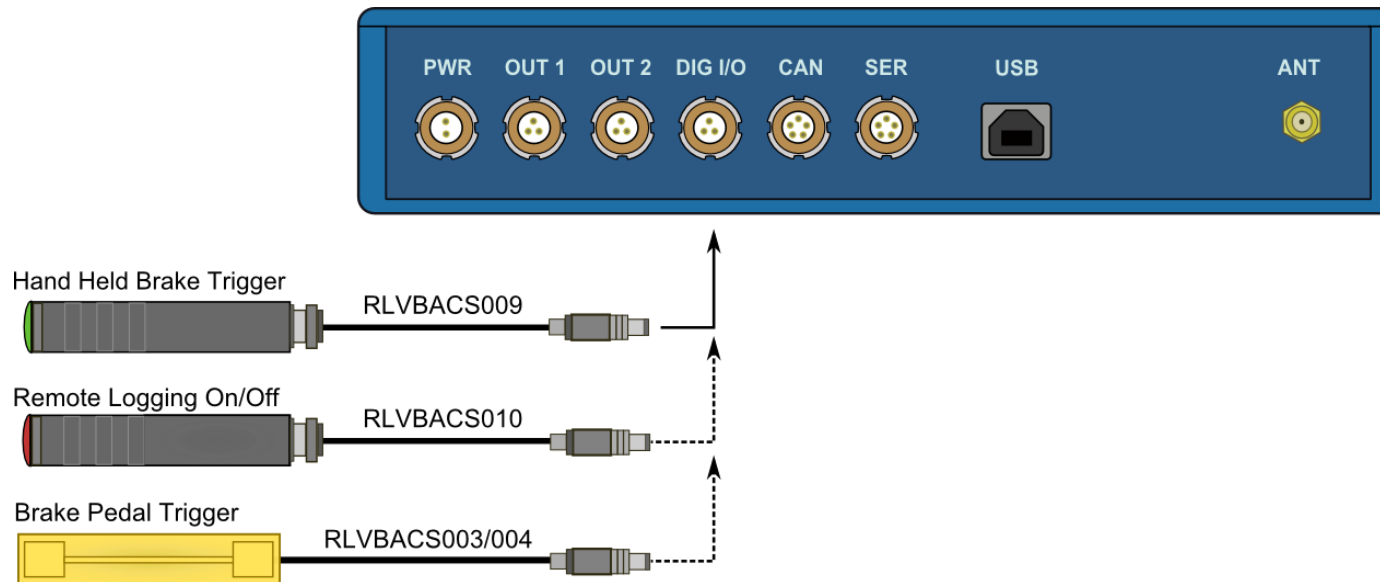

CAN / RS232 Ports / USB

The VB2SX10 is equipped with a CAN Bus interface, a RS232 serial port and an USB port. The RS232 port or USB is used for all communication between the VBOX and laptop PC. The USB or RS232 ports are able to transmit live data from the VBOX to the PC for viewing and performing real-time tests.

Note only the USB port is used for firmware upgrading

The CAN Bus port is available in either the socket labelled CAN or the socket labelled Serial. This CAN port has three functions, CAN Input in VCI mode, CAN Input in Racelogic Modules Mode (Internal Mode) and CAN output in Racelogic Modules Mode (External Mode).

VCI Mode:

This mode should be selected if you wish to log incoming CAN data from external modules from other manufacturers. Note in VCI mode no CAN output or connection to Racelogic modules is possible.

Racelogic Modules mode

This mode should be selected when Racelogic modules are connected to the VBOX or VBOX CAN output is required. Depending upon configuration, VBOX Tools software should be set as follows:

- **Internal Mode:** This mode should be selected when Racelogic input modules are connected to the VBOX. In this mode the CAN id's and Baud rate are non configurable.
- **External Mode:** This CAN mode should be used when a VBOX CAN data output is to be used by an external CAN device such as a Data acquisition system. In this mode the attributes of the CAN output stream are configurable by the user in VBOXTools

See the section 'Setup' in the VBOX software manual. Note that Internal Mode and External mode are not configurable from the front panel of the VB2SX10

The Socket labelled CAN also contains a secondary RS232 port for direct connections to the GPS engine for Local DGPS correction connection.

Using the USB cable

The first time you use the USB cable, you will need to follow the instructions below.

- Connect the USB cable between the VB2SX10 and your computer.
- Your computer will now recognise the presence of a new device, after a period of time a 'Found New Hardware Wizard' window will appear. See below.
- Click the option 'No, not this time' and click 'Next' (see image, right)
- A new window will appear at this window click 'Next' (see image, below)

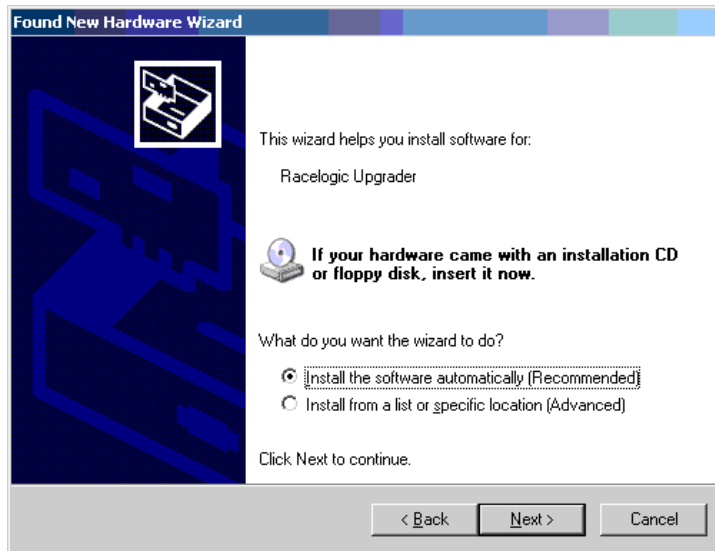

- A new 'Hardware Installation' window will appear. Click the button labelled 'Continue Anyway'.
- At the last window click 'Finish' to complete the installation.
- After a short period of time a window will ask you if you wish to reboot your computer, select 'NO'

Now disconnect the power from the VB2SX10 and then reconnect the power, your computer will now recognise the Slip angle sensor. When you run the VBOXTools software it will recognise the USB connections

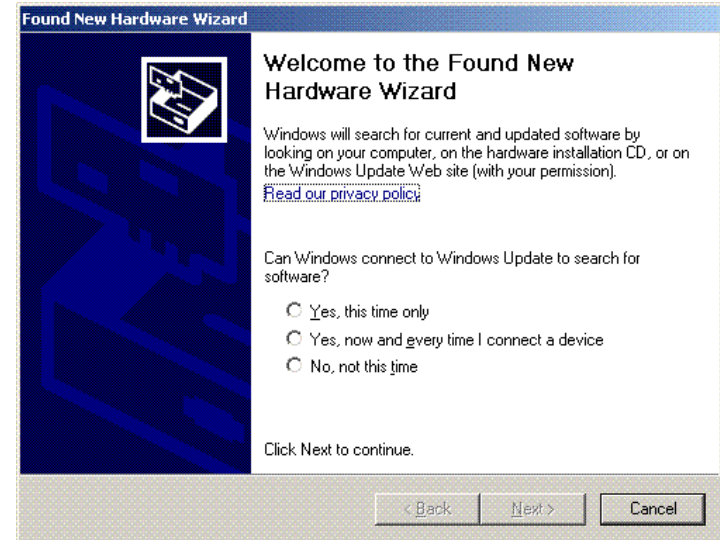

Getting Started

Required equipment (All supplied as standard unless specified)

- ❑ VB2SX10
- ❑ Fully charged battery pack or Cigar lighter 12v adapter lead
- ❑ GPS Antenna
- ❑ Blank SD card
- ❑ USB/RS232 Cable
- ❑ VBOX Software CD
- ❑ Laptop PC(not supplied)

1.Install Software

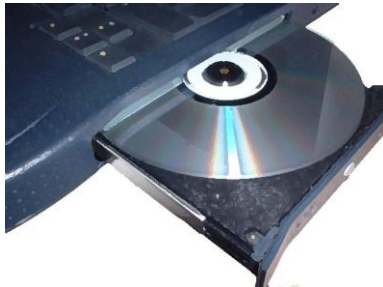

2.Place VBOX in vehicle



3.Fit antenna connector to VBOX



4. Mount GPS antenna on vehicle roof



5.Connect USB or serial cable (CAB01) to laptop



6. Connect other end of USB or serial cable to VBOX



7. Connect the power cable/ battery pack to the VBOX



8. If using 12v power cable, connect to vehicle



9. See below



9. With the power applied, the Display screen will illuminate. The VB2SX10 will start searching for satellites. The ST led will indicate the number of satellites currently in lock. For best results ensure the VBOX has acquired a lock on 5 or more satellites, essential for quality signal reception. When using the VBOX for the first time or when using the VBOX after a long period of time, allow the VBOX to sit for between 5 and 10 minutes to re-collect data needed to track satellites.

As the vehicle begins moving, the display will show a file-writing screen then show the normal display screen with the file name of the current file, with a small disc icon whenever the VBOX is logging.

VB2SX10 '.VBO' file format

The VB2SX10 data files are saved in standard space de-limited text format. This allows the data to easily be imported into third party applications such as word processors or spreadsheets. The files each contain a header section before the main data that describes the channel content and information about the VB2SX10 such as serial number and firmware version.

The [Column names] parameter specifies the data in each column of the data section.

An example of a VBOX VBO file is shown on the right.

Note that the File created time and date is derived from UTC time and date, so will not reflect your local time unless you logged data on the Greenwich Meridian.

```
File created on 16/11/2006 @ 15:42

[header]
satellites
time
latitude
longitude
velocity kmh
heading
height
Event 1 time

[channel units]

[comments]
(c)2001 - 2005 Racelogic
VBII SX10 V01.01 Bld. 0131
GPS Firmware : SX2g

Serial Number : 00007194
Log Rate (Hz) : 10.00
Kalman Filter - Pos : 0 Vel : 0
GPS Time

[module Information]

[column names]
sats time lat long velocity heading height event-1

[data]
006 154215.35 +3119.240616 +00058.826374 000.000 000.00 +0158.13 0.00000
006 154215.40 +3119.240620 +00058.826371 000.820 326.60 +0158.12 0.00000
006 154215.45 +3119.240624 +00058.826378 000.000 000.00 +0158.13 0.00000
006 154215.50 +3119.240626 +00058.826378 000.000 000.00 +0158.12 0.00000
006 154215.55 +3119.240625 +00058.826380 000.000 000.00 +0158.13 0.00000
006 154215.60 +3119.240621 +00058.826378 000.000 000.00 +0158.12 0.00000
006 154215.65 +3119.240619 +00058.826379 000.000 000.00 +0158.12 0.00000
006 154215.70 +3119.240620 +00058.826381 000.000 000.00 +0158.13 0.00000
006 154215.75 +3119.240622 +00058.826380 000.000 000.00 +0158.12 0.00000
006 154215.80 +3119.240624 +00058.826382 000.000 000.00 +0158.12 0.00000
006 154215.85 +3119.240627 +00058.826378 000.000 000.00 +0158.12 0.00000
006 154215.90 +3119.240627 +00058.826375 000.000 000.00 +0158.12 0.00000
```

VBOXTools Software

The VBOXTools software is used for configuration of the VB2SX10 and also for analysis of the VBO data files.

For further information on the VBOXTools software refer to the VBOXTools Software manual supplied with VB2SX10.

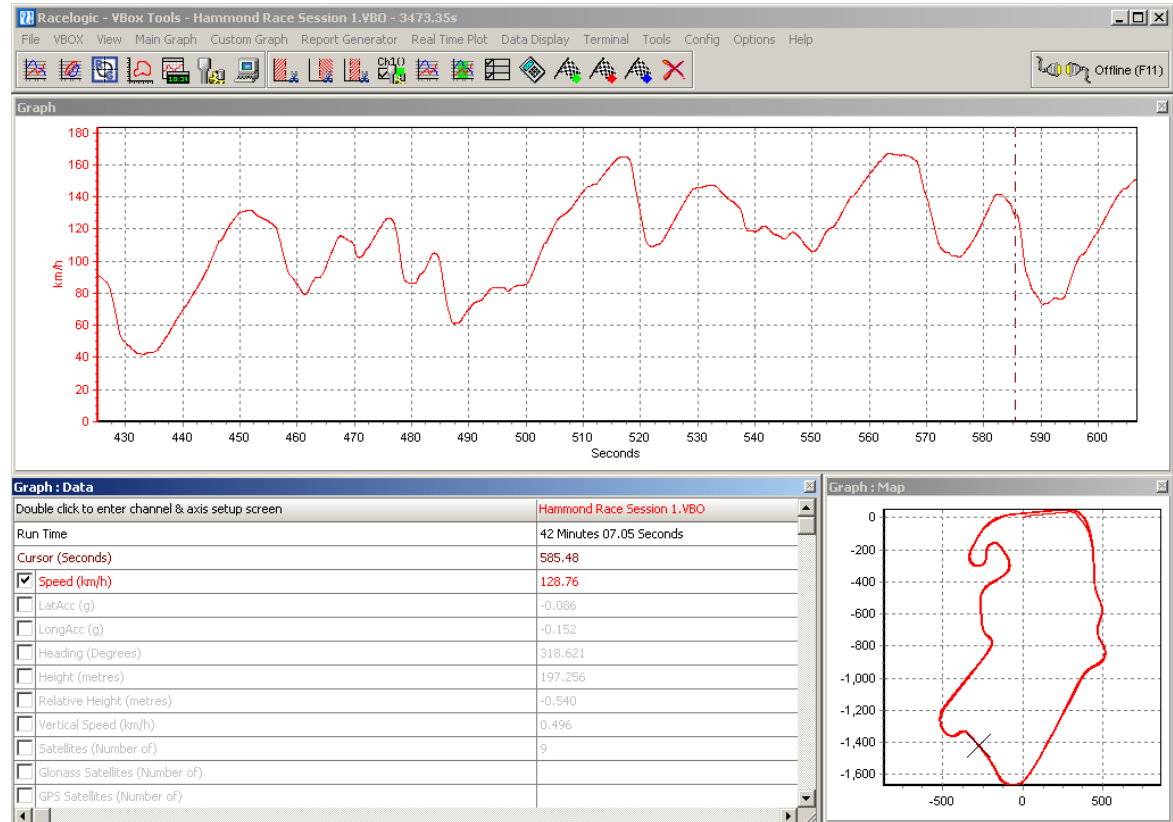

Upgrading the Firmware

Occasionally Racelogic releases new versions of firmware code for VBOX products, this maybe to fix bugs or to add new features. New firmware for the VB2SX10 is loaded into the unit using a computer and the supplied USB cable.

The latest firmware upgrade (.ruf) file for the Speed Sensor is available from the Racelogic website in the VBOX downloads section.

<http://www.racelogic.co.uk/2003/vbox/downloads.htm>

If you need the latest file, download it from the website and copy it to your computer.

If you are connecting your slip angle sensor to your computer with the USB cable for the first time then follow the instructions in the Section 'Using the USB cable' earlier in this manual before following the instructions below.

How to upgrade the firmware

- Press and hold the '◀' button whilst the power is connected to the VB2SX10.
- The screen will now display the UPGRADER screen, showing that it is ready for upgrading
- Connect the USB cable to your computer.
- Double click on the .ruf firmware upgrade file that you have downloaded from the website
- This will automatically run the upgrade program where you will see the progress of the upgrade.
- At the end of the process disconnect the USB and then disconnect and reconnect the power.

If you have any questions regarding upgrade of VBOX, please do not hesitate to contact support@racelogic.co.uk

Specification

GPS	
Velocity	
Accuracy	0.1 Km/h (averaged over 4 samples)
Units	Km/h or Mph
Update rate	10 Hz
Maximum velocity	1000 Mph
Minimum velocity	0.1 Km/h
Resolution	0.01 Km/h
Absolute Positioning	
Accuracy	3m 95% CEP**
Accuracy with DGPS	1.8m 95% CEP**
Update rate	10 Hz
Resolution	1 cm
Heading	
Resolution	0.01°
Accuracy	0.1°
Acceleration	
Accuracy	0.5%
Maximum	20 G
Resolution	0.01 G
Update rate	10Hz
Memory	
SD/MMC Card	
Recording time	Dependent on flash card capacity*
* Approximately 2.2Mb per hour used when logging GPS data at 10Hz	
Distance	
Accuracy	0.05% (<50cm per Km)
Units	Metres / Feet
Update rate	10Hz
Resolution	1cm
Height accuracy	6 Metres 95% CEP**
Height accuracy with DGPS	2 Metres 95% CEP**
Brake Stop Accuracy	
Accuracy	+/-20cm
Time	
Resolution	0.01 s
Accuracy	0.01 s
Power	
Input Voltage range	6v-30v DC
Current	Typically 560mA
Environmental and physical	
Weight	Approx500 grammes
Size	119mm x 128mm x 30mm
Operating temperature	-30°C to +60°C
Storage temperature	-40°C to +80°C
Definitions	
** CEP = Circle of Error Probable	
95% CEP (Circle Error Probable) means 95% of the time the position readings will fall within a circle of the stated diameter	

Outputs			
CAN Bus			
Bit rate	125Kbits, 250Kbits, 500Kbits & 1Mbit selectable baud rate		
Identifier type	Standard 11bit or extended 2.0A		
Data available	Satellites in View, Latitude, Longitude, Velocity, Heading, Altitude, Vertical velocity, Distance, Longitudinal acceleration & lateral acceleration, Distance from trigger, Trigger time, trigger Velocity		
Analogue		Digital	
Voltage range	0 to 5Volts DC	Frequency range	DC to 44.4Khz
Default setting *	Velocity 0.0125Volts per Km/h (0 to 400Km/h)	Default setting *	25Hz per Km/h (0 to 400Km/h)
Accuracy	0.1 Km/h		90 pulses per metre
Update rate	10Hz	Accuracy	0.1Km/h
		Update rate	10Hz
<i>* The range settings can be adjusted by the user in software or via the front panel buttons</i>			

Inputs	
CAN Bus	
VCI CAN mode	Up to 16 channels from any external CAN module
Racelogic modules mode	Up to 24 channels from any combination of ADC02, ADC03, FIM02, TC8, Yaw sensor or CAN02
Digital	
Brake/Event Trigger	Selectable signal polarity. 16bit timer capture with 5µs resolution
On/Off Logging control	Remote log control from hand-held switch

Connector Assignments



Connector 1 POWER (Dedicated 4.5V to 36V DC Power Connector)

Pin	I/O	Function
1	I	Power +
2	I	Ground
Chassis	I	Ground

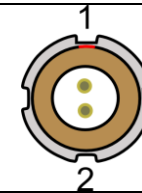

Connector 2 / 3 – OUT 1 / OUT 2 (One Analogue and One Digital Output Each)

Pin	I/O	Function
1	O	Analogue Out 1 / 2
2	O	Digital Out 1 / 2
3	I	Ground
Chassis	I	Ground

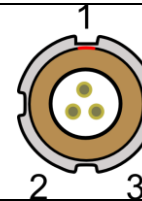

Connector 4 – DIG I/O (Wheel Speed and Brake Trigger Inputs)

Pin	I/O	Function
1	I	Wheel Speed (not available yet)
2	I	NC
3	I	Brake Trigger
Chassis	I	Ground

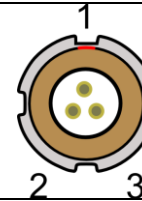

Connector 5 – CAN (First CAN Bus Connector, Serial Connection to GPS Engine)

Pin	I/O	Function
1	O	RS232 Tx GPS (Tx Data from GPS engine)
2	I	RS232 Rx GPS (Rx Data to GPS engine)
3	I/O	CAN High (Also direct connection to Connector 6 CAN High)
4	I/O	CAN Low (Also direct connection to Connector 6 CAN Low)
5	I/O	Power +
Chassis	I	Ground

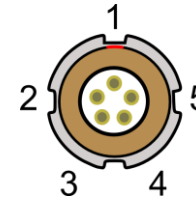

Connector 6 – SERIAL (Setup / Upgrade, Second CAN Bus Connector)

Pin	I/O	Function
1	O	RS232 Tx Serial Data transmit
2	I	RS232 Rx Serial Data receive
3	I/O	CAN High (Also direct connection to Connector 5 CAN High)
4	I/O	CAN Low (Also direct connection to Connector 5 CAN Low)
5	I/O	Power +
Chassis	I	Ground

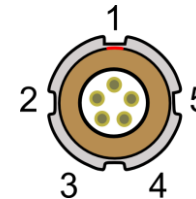

Connector 7 – USB (Setup / Upgrade)

Pin	I/O	Function
1		
2	I/O	USB-
3	I/O	USB+
4	I/O	Ground
Chassis	I	Ground



Connector 8 / 9 – ANT A / ANT B (GPS Antenna A / B)

Pin	I/O	Function
1	I	Signal
Chassis	I	Ground





CAN Bus Data Format

Format		Motorola							
ID*	Update Rate	Data Bytes							
		1	2	3	4	5	6	7	8
0x301	50ms	(1) Sats in view		(2) Time since midnight UTC		(3) Position – Latitude DDMM.MMMMM			
0x302	50ms	(4) Position – Longitude DDMM.MMMMM				(5) Velocity. (Knots)		(6) Heading (Degrees)	
0x303	50ms	(7) Altitude. WGS 84. (Metres)			(8) Vertical velocity. (M/S)		Unused	(9) Status	(10) Status
0x304	50ms	(11) Distance. (Metres)				(12) Longitudinal Accel. (G)		(13) Lateral Accel. (G)	
0x305	50ms	(14) Distance travelled since VBOX reset (Metres)				(15) Trigger time		(16) Trigger Velocity (Knots)	

* Default Identifiers. The identifier values can be changed using the configuration software.

- (1) If Satellites in view < 3 then only Identifier 0x301 transmitted and bytes 2 to 8 are set to 0x00.
- (2) Time since midnight. This is a count of 10ms intervals since midnight UTC. (5383690 = 53836.90 seconds since midnight or 14 hours, 57 minutes and 16.90 seconds).
- (3) Position, Latitude * 100,000 (515924579 = 51 Degrees, 59.24579 Minutes North). Latitude highest bit indicates north/south hemisphere. 0=north, 1=south, Bit 7 in Status is also set.
- (4) Position, Longitude * 100,000 (5882246 = 0 Degrees, 58.82246 Minutes West). Longitude highest bit indicates east/west of Greenwich meridian. 0=west,1=east. Bit 6 in Status is also set.
- (5) Velocity, 0.01 knots per bit.
- (6) Heading, 0.01° per bit.
- (7) Altitude, 0.01 meters per bit, signed.
- (8) Vertical Velocity, 0.01 m/s per bit, signed.
- (9) Status. 8 bit unsigned char. Bit 0=VBOX Lite, Bit 1=Open or Closed CAN Bus (1=open), 2=VBOX3.
- (10) Status is an 8 bit unsigned char. Bit 0 is always set, Bit 3=brake test started, Bit 4 = Brake trigger active, Bit 5 = DGPS active.
- (11) Distance, 0.000078125 meters per bit, unsigned.
- (12) Longitudinal Acceleration, 0.01G per bit, signed.
- (13) Lateral Acceleration, 0.01G per bit, signed.
- (14) Distance travelled in meters since VBOX reset.
- (15) Time from Trigger event to Zero Km/h.
- (16) Velocity at brake trigger point in Knots.

The VBOX CAN database is available in Vector Database (DBC File) format from the Racelogic VBOX website.

Module Dimensions

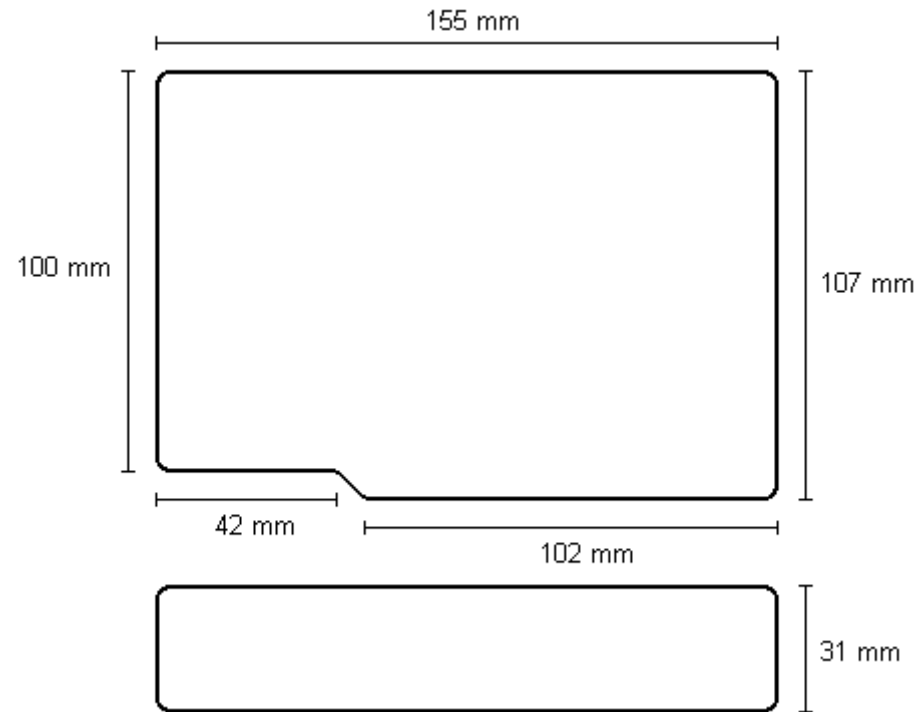

Fuse Reset Button

The VB2SX10 contains a fuse to protect it from excessive currents. If the unit is accidentally subjected to large currents and the fuse has become tripped, it can be reset by pressing the button marked 'Fuse Reset' all the way into the unit with a long, thin implement.

Contact Information

Racelogic Ltd
Unit 10 Swan Business Centre
Osier Way
Buckingham
MK18 1TB
UK

Tel: +44 (0) 1280 823803

Fax: +44 (0) 1280 823595

Email: support@racelogic.co.uk

Web: www.racelogic.co.uk

Revision	Date	Description	Author
1	09/02/07	First release	JH
2	05/06/07	Inclusion of Declaration of Conformity Statement	CAS
3	27/06/07	Updated for f/w V01.01b0194 (mainly new or changed front panel options)	JH
4	03/12/07	Addition of Format: Motorola to CAN Bus Data Format table	NT
5	30/04/08	Updated Racelogic contact information	JH
6	09/07/08	Added VCI mode where applicable. Updated menu structure P.8 – P.11	NT
7	19/01/12	Updated Inventory, images and general content.	LN
8	11/02/13	Updated card format section. P11.	LN